

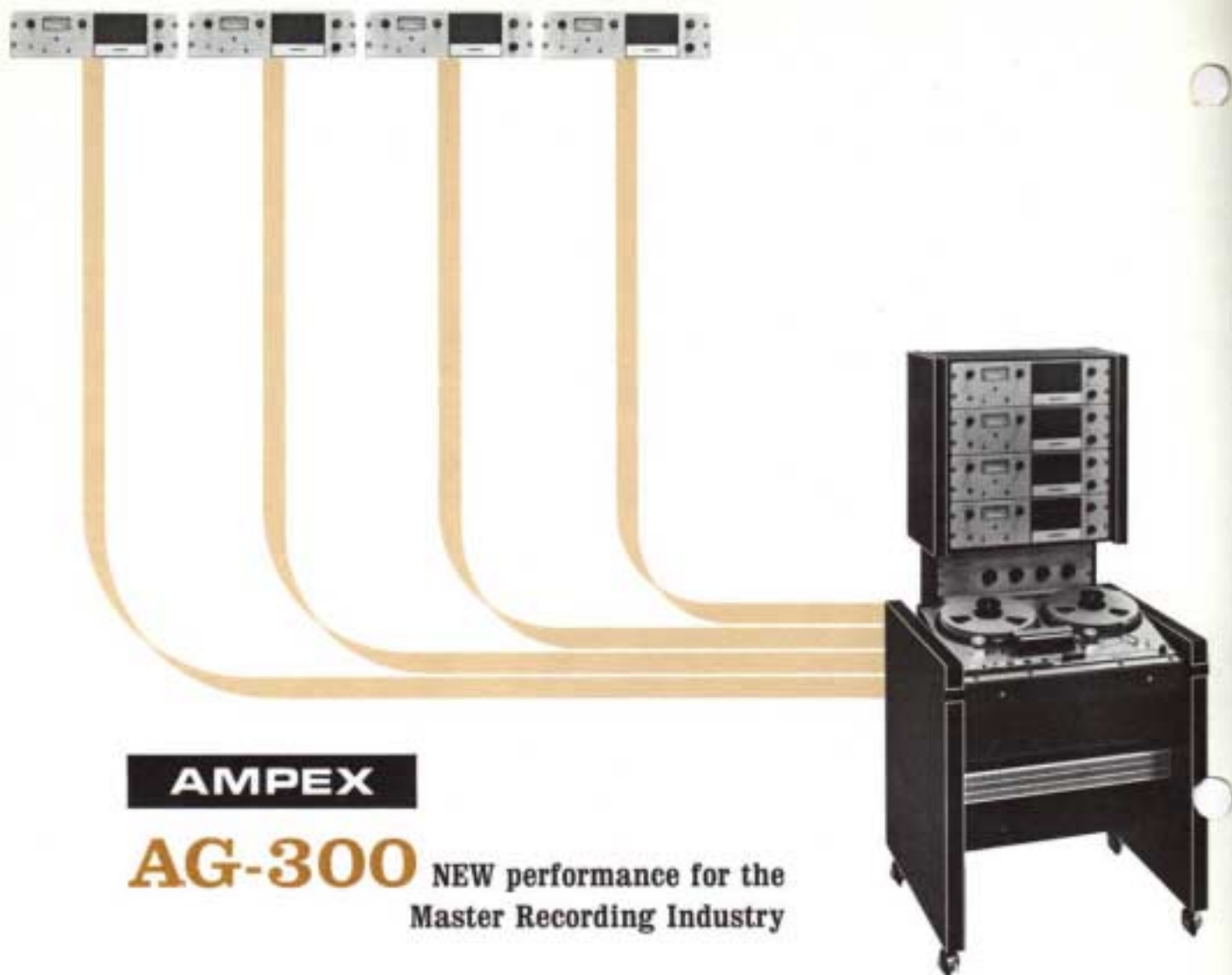

**AMPEX**  
SOLID STATE  
**AG-300**

A new, improved series  
of the world's best known Master Recorders



**AMPEX**

**AG-300** NEW performance for the  
Master Recording Industry

WHAT IS A MASTER RECORDER?

- 1• *It is a professional instrument designed specifically for Master Recording Studios who make master tapes for phonograph records and recorded tapes.*
- 2• *It must have superior electronic and mechanical specifications. (Since the ultimate listener of the phonograph record or recorded tape may receive the 4th or 5th generation recording, any limitations or imperfections in the original master would be greatly compounded in succeeding generations.)*
- 3• *It must have an extremely rigid tape transport (to eliminate flexing) to insure exact component alignment throughout the life of the recorder.*
- 4• *It should have multi-channel recording capability (three, four, or more channels) to provide maximum flexibility and balancing in mixing and mastering.*

INTRODUCING THE NEW  
SOLID STATE  
**AG-300**  
MASTER RECORDER

Ampex presents a new and advanced solid state version of the famous 300 series master recorder. (Ampex 300 series recorders have gained world-wide recognition during the last 17 years as the "standard of the master recording industry," and are used by virtually all major recording studios throughout the world.)

In addition to the time proven reliability of 17 years, the new AG-300 offers:

- a. *Newly designed solid state electronics for greater reliability and performance.*
- b. *A rigid tape transport reinforced in the critical alignment area with a massive 2" die-cast frame that eliminates flexing and maintains precision alignment of components.*
- c. *New modern, functionally designed transport, electronics and console.*
- d. *Greater operational convenience and simplified maintenance.*
- e. *Multi-Channel Recording Capability.* Nearly universal in all professional master recording studios, three or four channel recording provides flexibility and unique advantages that:

*Reduce cost in recording sessions by permitting re-balancing orchestral sections and soloists after the session. Reverberation and extra equalization can be added to the separate instrumental or vocal sections to achieve desired results. Rarely is there a need to call back the performers for another "take" because of poor musical balance.*

*Improve quality by eliminating the "hole-in-the-middle" effects of two channel stereo recording. Additional channels and microphones provide for optimum recording and proper separation of each musical segment.*

*Permits easy mixing (and experimentation) of the channels into any desired balance combination.*

*If the first "mixed" master is not completely satisfactory, it can be re-recorded from the original multi-channel master as many times as necessary with a different balance each time until the desired perfection is obtained.*

*Allow for Special Effects* such as "sound-on-sound," echo, bass, or reverberation through use of SEL-SYNC\* synchronizer. This permits **one performer** to sing with himself and create perfect duets, trios, etc. Special effects can be produced with each channel separately, if desired, thus limiting the effects to certain selected parts of the orchestra or to the soloist.

*SEL-SYNC selective synchronizer is a valuable Ampex feature that is optional on the AG-300SS three and four track (or more) Master Recorders. Its unique switching system converts any single or combination of recording track heads into temporary playback heads while recording continues on the remaining tracks. Therefore, time lag is eliminated between what is heard and what is being recorded. With this system a soloist may be added on one or more tracks in perfect synchronization with what has already been recorded. (Example: a four channel AG-300-4 with SEL-SYNC synchronizer permits a single artist to perform all parts of a quartet and each part will be an **original** master track.)*

TOP VIEW

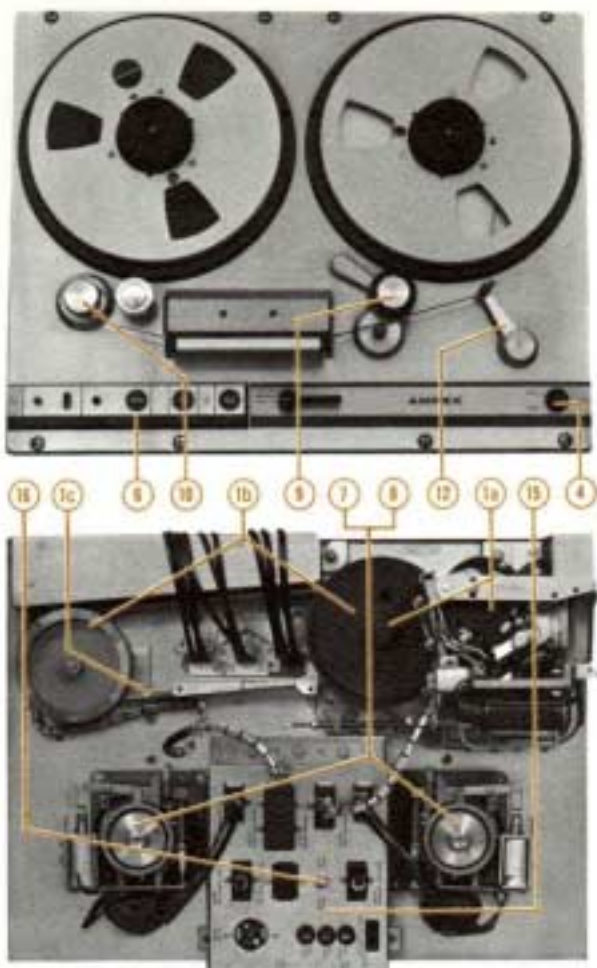

## **AMPEX** AG-300 PRECISION TAPE TRANSPORT

*Over 2500 Ampex 300 master recorders have been installed throughout the world. In addition to master recording, many instrumentation recorders use the 300 series transport because of its high mechanical performance, reliability, ruggedness and long life.*

*Most of the original 300 series recorders are still in use today, presenting long term economy that is unequalled in revenue-producing equipment for other types of business. This fact alone makes it possible for the recording studio to enjoy the advantages and added capabilities of the more sophisticated three or four channel mastering recorder.*

### TAPE TRANSPORT FEATURES

- Flutter and wow are minimal due to:
  - Precision capstan drive
  - Massive flywheels
  - Addition of a heavy casting to the underside of the top plate to assure rigidity in critical area of capstan drive, heads, reel idlers, and tape guiding components.
- Flutter and wow are substantially below audibility even after the 4th or 5th generation.
- Exceptional tape stability and precision is still maintained after years of constant service.
- Equalization is changed automatically when tape speed is changed.
- Record, Start, and Stop modes can be remote controlled.
- Record button is located on the transport for easy operation.
- Differential braking system provides smooth stops without stretching tape.
- Brakes are self-limiting design with stainless steel drums to provide long wear and high reliability.
- Precision capstan idler provides accurate traction pressure through positive solenoid control and disengages automatically when power is shut off.
- Reel idler has heavy-mass flywheel to provide essential filtering. This, plus precision capstan assembly and hysteresis synchronous motor, holds wow and flutter to absolute minimum.
- Indirect drive system smooths out momentary disturbances through the added damping of the rim drive.
- Take-up tension arm eliminates tape bounce, permits smooth, even tape wrap, and provides automatic stop at end of reel.
- Fast starts: tape is up to full speed in  $\frac{1}{10}$  second for  $\frac{1}{4}$ " tapes and  $\frac{1}{2}$  second for  $\frac{1}{2}$ " tapes.
- Fast stops: less than 2" of tape travel after pushing stop button (at 7½ ips).
- Control Circuit Box centralizes all relays and switching circuits in a single unit. All switches and relays are oversize for positive, long-life operation. There is no open wiring on underside of tape deck to create shock hazard.
- "Fast Start"/"Slow Start" switch allows capstan motor to stay "on" when tape is threaded, or "off" when equipment is in "standby" condition for long periods. (In latter position motor operates only after START button is depressed.)

## ELECTRONICS FEATURES

New 100% solid state design provides proven reliability and advantages of transistors.

- Trouble free, long life
- Cool operation
- Low power consumption
- Plug-in transistors are standard types — readily available and easily changed.

Plug-in equalizers for maximum flexibility.

Convenient front panel adjustments.

Record/Safe switch.

Gain controls are locking type.

Record mode indicator lights.

Phone monitor jack.

Plug-in microphone pre-amps, optional. (Most studios feed microphones through a mixing console to the recorder. Therefore, microphone pre-amps are not built into the AG-300 series but are available as accessories to users going directly into recorder. See accessory section.)

## HEAD ASSEMBLY FEATURES

New head gate assembly. Gate opens wide for easy editing, cleaning and threading.

New ferrite-type erase head significantly improves erase characteristics.

Record and playback heads are individually mu-metal shielded for maximum hum rejection and minimum cross-talk.

Non-wearing glass tape lifters. Permit "touch cueing" to locate material in fast forward or rewind.

Easy threading.

Positive, self-locking head adjustments for azimuth and zenith.

Head assembly is easily removed by removing two screws and unplugging head cable.

## ELECTRONICS SOLID STATE

*The 100% solid state circuitry in the AG-300 was developed from the same technology and experience that has kept Ampex the leader in magnetic recording for over 18 years. This is a newly designed electronics that takes maximum advantage of the capabilities and reliability inherent in transistors and sets a new level of performance in a master recorder.*

## HEAD ASSEMBLY

*Ampex' exclusive technical mastery in producing magnetic recording heads with unmatched performance and long life, is based on more than 18 years experience in manufacturing magnetic heads for professional audio, instrumentation and video tape recorders. This technical mastery is fully utilized in producing the high precision multi-channel recording heads for today's master audio and instrumentation recorders.*

### SOLID STATE ELECTRONICS

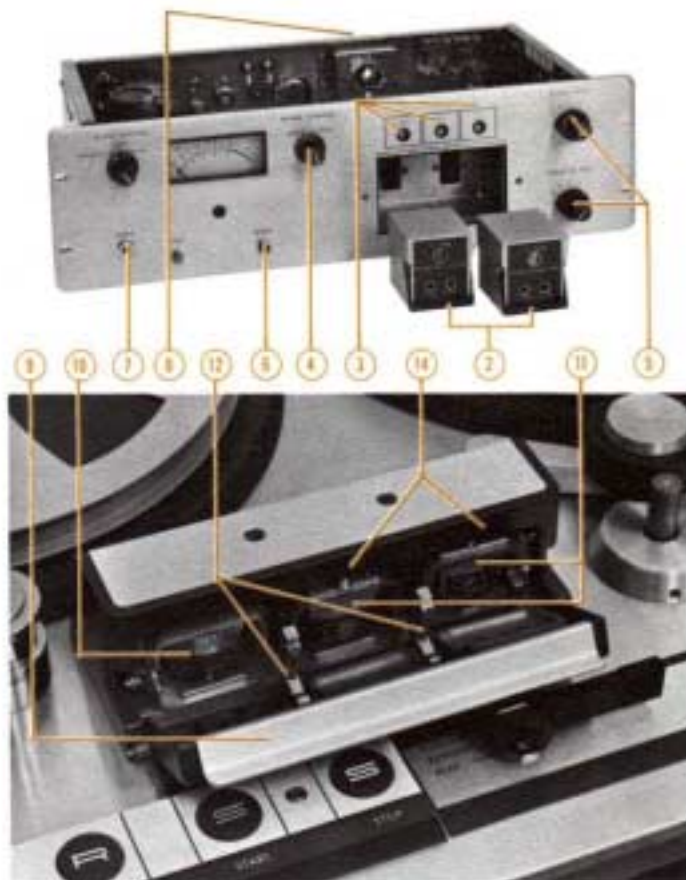

HEAD ASSEMBLY

**WIDE RANGE OF MODELS AND ACCESSORIES to meet all Master Recording requirement**

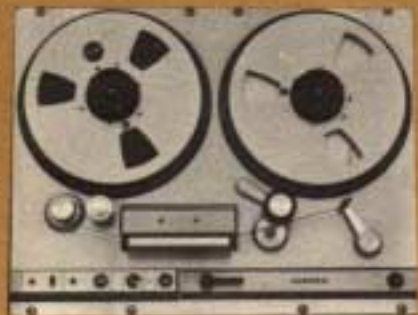

AG-300 SERIES

**Standard Models** All with in-line heads, dual speed 7 1/2 and 15 ips.

**AG-300** — single channel, full track, 1/4" tape width.

**AG-300-2** — two channel, 1/4" tape width.

**AG-300-3 and -4** — three and four channel, 3/8" tape width, with or without SEL-SYNC synchronizer.

**Special Models** AG-300-6 and 8 — six and eight channel, with or without SEL-SYNC synchronizer. Special head configurations and operating speeds from 1 1/2 to 30 ips are also available.

**AG-300-2M** — two channel, 1/4" tape width (special heads for four track masters).

**Mounting** All models up to four channels available mounted in consoles, or unmounted for rack or custom installation.

SPEAKER-AMPLIFIER  
MODEL 622



MIXER/MODEL MX-10



SEL-SYNC SYNCHRONIZER PANEL



LINE INPUT  
TRANSFORMER



RECORD/REPRODUCE  
EQUALIZERS

## ACCESSORIES

### AG-300 SERIES

#### FOUR-POSITION STEREO HEAD ASSEMBLY:

(for AG-300 series). Fits into same space as standard 3-position stereo assembly, adds 4-track playback head. Completely assembled unit (1½" tape only).

#### MIXER — MODEL MX-10

Four position, two channel mixer, feeds 4 mike, or 2 mike and 2 line inputs to either or both channels. Unmounted. For Ampex recorders and general use.

#### SPEAKER/AMPLIFIER — MODEL 622

Ideal portable monitor for professional recorders. Gives studio sound in compact and convenient size. Matched 8" speaker enclosure, and 10 watt push-pull amplifier.

#### MICROPHONE PREAMPS

Required for direct microphone use with AG-300 series recorders, also AG-350-1, -2; AG-100; plug-in type, one per channel required, low impedance input. 40 db/60 db switchable.

#### LINE INPUT TRANSFORMERS

For AG-300 series recorders (also AG-350-1, -2; AG-100; MX-10), plug-in type, one per channel as required.

Balanced bridging — Matching 600 ohm.

#### RECORD/REPRODUCE EQUALIZERS FOR:

AG-300, AG-350-1, -2 (plug-in type, are supplied with each recorder as ordered).

Additional equalizers are available:

15 NAB	4020252-01
15 CCIR	4020252-04
7½ NAB	4020252-02
7½ CCIR	4020252-05
3¾ (120 µsec)	4020252-03
30 (17.5 µsec)	4020252-06

#### SEL-SYNC SYNCHRONIZER PANEL

For 3 channel — For 4 channel

#### MAINTENANCE ACCESSORIES

Head demagnetizer  
Head Cleaner, 4-Oz. can  
Lubricating Oil, in plastic oiler bottle  
Operation and maintenance manuals  
(furnished with recorder) AG-300 Series

#### ALIGNMENT TAPES

See separate Alignment Tape Price Schedule for additional tapes and detailed program content.

¼ inch — Reproduce Alignment Tape

15 ips, NAB µ/sec, Full track

7½ ips, 50 µ/sec, Full track

3¾ ips, 120 µ/sec, Full track

¾ inch — Calibrated Flutter Test Tape

15 ips, 3 KC only, with meter calibration segment

7½ ips, 3 KC only, with meter calibration segment

## SPECIFICATIONS

### FREQUENCY RESPONSE

15 ips	±2 db	30-18,000 cps
7½ ips	±2 db	40-10,000 cps
	±2 -4 db	30-15,000 cps

### SIGNAL-TO-NOISE (Peak record level to unweighted noise)

Model	Tracks	3¾	7½	15
AG-300-1 U or C ¼"	Full	59 db	64 db	64 db
AG-300-1 U or C ¼"	Half	56 db	60 db	60 db
AG-300-2 U or C ¼"	Two	56 db	60 db	60 db
AG-300-3 U or C ½"	Three	—	62 db	62 db
AG-300-4 U or C ½"	Four	—	60 db	60 db

Peak record level defined as highest level at which overall (input to output) total rms harmonic distortion does not exceed 3% when measured on 400 cycle tone. Noise is measured when erasing signal of peak recording level in absence of new signal. Thus, bias and erase noise are included as well as playback amplifier noise. All frequencies measured from 50-15,000 cycles (using 3M-201 tape or equivalent).

### FLUTTER AND WOW

15 ips — less than .07% rms; 7½ ips — less than .14%. Measured in accordance with ASA Z57.1 — 1954 standard, measuring all frequencies between .5-250 cps.

### CROSS TALK REJECTION

50 db on standard Multi-Channel models at 500 cycles.

### STARTING TIME

To full speed: ½ sec. for ¼" tape  
½ sec. for ½" tape

### STOPPING TIME

15 ips — 2" of tape past heads  
7½ ips — 1" of tape past heads

### TIME ACCURACY

0.2% or +3.6 sec. for 30 min. recording

### REWIND TIME

1 min. approx. for full 10½" reel (2400 ft.)

### CONTROLS

Stop, Start, Record — pushbutton, relay operated; remote control optional. Normal Play, Fast Forward, Rewind — on selector switch. Operation of Record button on tape transport actuates record relays on all channels. Record-Safe switch on electronics.

### MONITORING

Independent record and playback systems allow tape to be monitored while recording.

### EQUALIZATION

All standard models supplied with NAB equalization. CCIR curves available on special order.

### RECORD INPUT

100k bridging — 18 dbm to produce recommended operating level.

### PLAYBACK OUTPUT

+8 dbm into 600 ohms — re-arrangeable for +4 dbm output, balanced or unbalanced. Maximum of +28 dbm before clipping.

### POWER INPUT REQUIRED

117 volts, 60 cycles (also available for 50 cycles). Single channel recorders require 2.5 amperes, add 0.15 ampere for each additional channel.

## UNCRATED WEIGHTS & DIMENSIONS

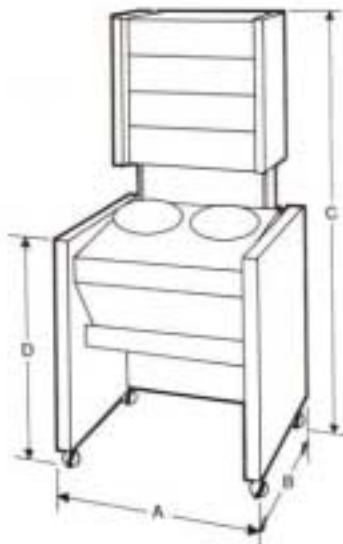
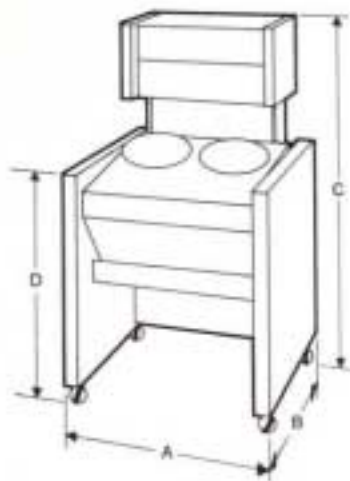
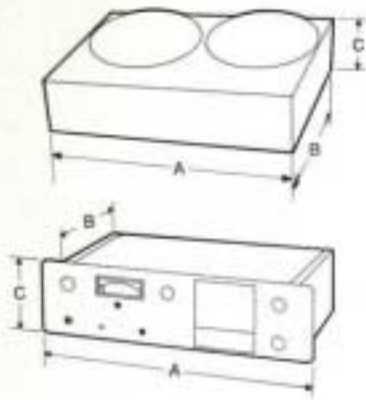

DIMENSION	A	B	C	D	UNCRATED WEIGHT (POUNDS)
Transport only	24 1/2" 60.2 cm	19" 48.3 cm	10 1/2" 26.7 cm	—	70 31.8 kg
AG-300 Electronics only	19" 48.3 cm	9" 22.9 cm	5 1/4" 13.3 cm	—	17 7.6 kg
Single Channel in console	28 1/4" 73.0 cm	26" 66.0 cm	51 1/2" 130.8 cm	32 1/2" 82.6 cm	168 76.4 kg
Two Channel in console	28 1/4" 73.0 cm	26" 66.0 cm	51 1/2" 130.8 cm	32 1/2" 82.6 cm	184 83.6 kg
Three Channel in console	28 1/4" 73.0 cm	26" 66.0 cm	62" 157.5 cm	32 1/2" 82.6 cm	202 91.8 kg
Four Channel in console	28 1/4" 73.0 cm	26" 66.0 cm	62" 157.5 cm	32 1/2" 82.6 cm	218 99.1 kg

NOTE: All weights are approximate.

# AMPEX

## AMPEX CORPORATION

401 Broadway • Redwood City • California • 94063

North Sydney, Australia • Rio de Janeiro, Brazil • Toronto, Canada • Bogota, Colombia  
 • Reading, England • Paris, France • Frankfurt/Main, Germany • Hong Kong, B.C.C.  
 • Tokyo, Japan • Mexico City, Mexico • Stockholm, Sweden • Lugano, Switzerland